

ENVIROSEP 600 Litre Grease Interceptor

Drawing No.
CP023

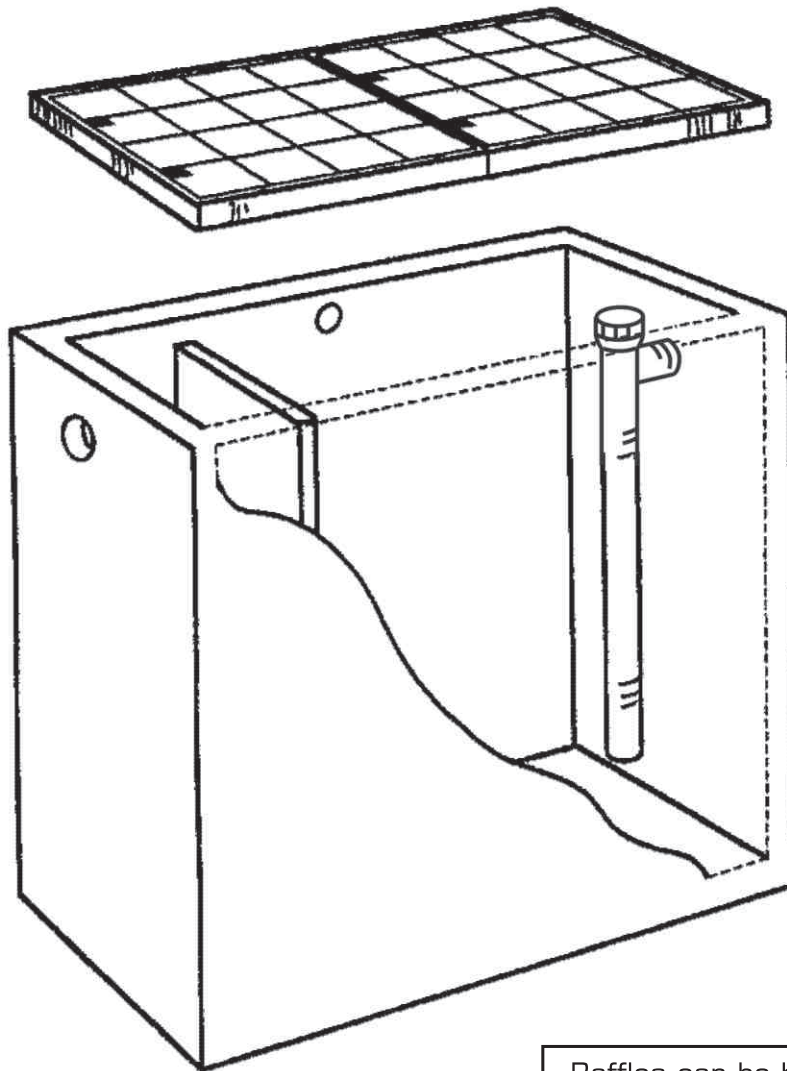

Dimensions (in Millimetres)

Length	1750
Width	1100
Height	835

Bottom of Tank to bottom
of Inlet 600 external

Excavation Details

Length	1900
Width	1300

Lay unit on 75mm
Deep Compacted Sand
if required.

Depth with Lids

Light Duty	893
Medium Duty	918
Heavy Duty	918

All dimensions +/- 20mm

Baffles can be built into Trade Waste
Pits so that they can be used for
Storm Water Retention Pits

TITLE: 600 Litre Grease Interceptor	
Scale NTS	DATE 5 / 3 / 99
	DRW BY <i>[Signature]</i>
Drawing No CP023	CHECKED BY <i>[Signature]</i>
	DATE 5 / 3 / 99

Colac Cement Products PTY LTD
Address: 21 Forest Street Colac, Victoria, 3250 Australia
Phone: (03) 5231 5231
Fax: (03) 5232 2744