

ENVIROSEP 3000 Litre Petrol & Oil Interceptor

Drawing No.
CPO35

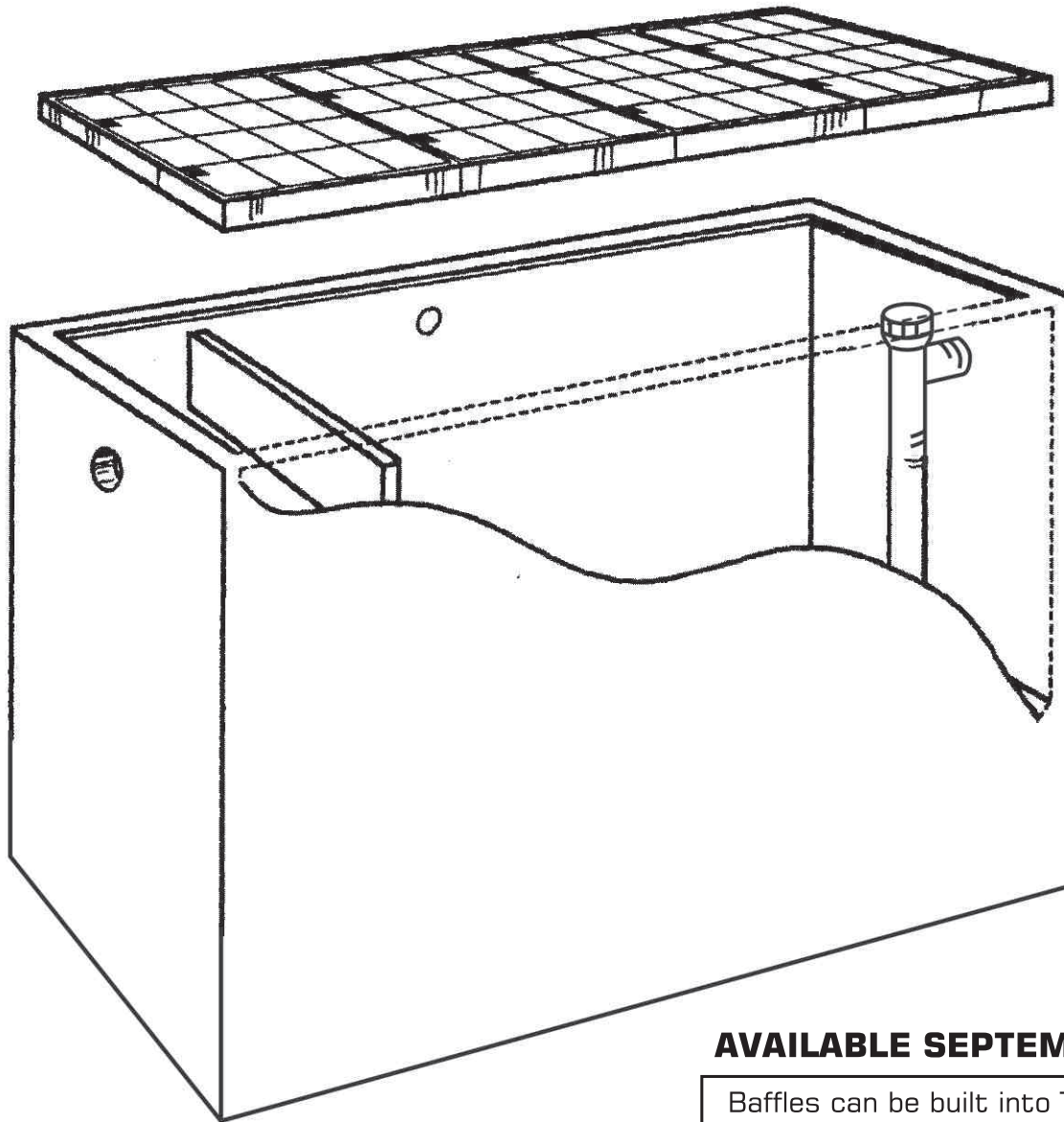

Dimensions (in Millimetres)
External

Length	2800
Width	1050
Height	1900

Bottom of Tank to bottom
of Inlet 1550 external

Excavation Details

Length	3000
Width	1200

Lay unit on 75mm
Deep Compacted Sand
if required.

Depth with Lids

Light Duty	1958
Medium Duty	1983
Heavy Duty	1983

All dimensions +/- 20mm

AVAILABLE SEPTEMBER 2005

Baffles can be built into Trade Waste
Pits so that they can be used for
Storm Water Retention Pits

Title: 3000 L Petrol & Oil Interceptor

Scale NTS	DATE 5 / 3 / 99
	DRW BY <i>[Signature]</i>
Drawing No. CPO35	CHECKED BY <i>[Signature]</i>
	DATE 5 / 3 / 99

Colac Cement Products PTY LTD

Address: 21 Forest Street Colac, Victoria, 3250 Australia
Phone: (03) 5231 5231
Fax: (03) 5232 2744