

# ENVIROSEP 2000 Litre Grease Interceptor

Drawing No.  
CP026

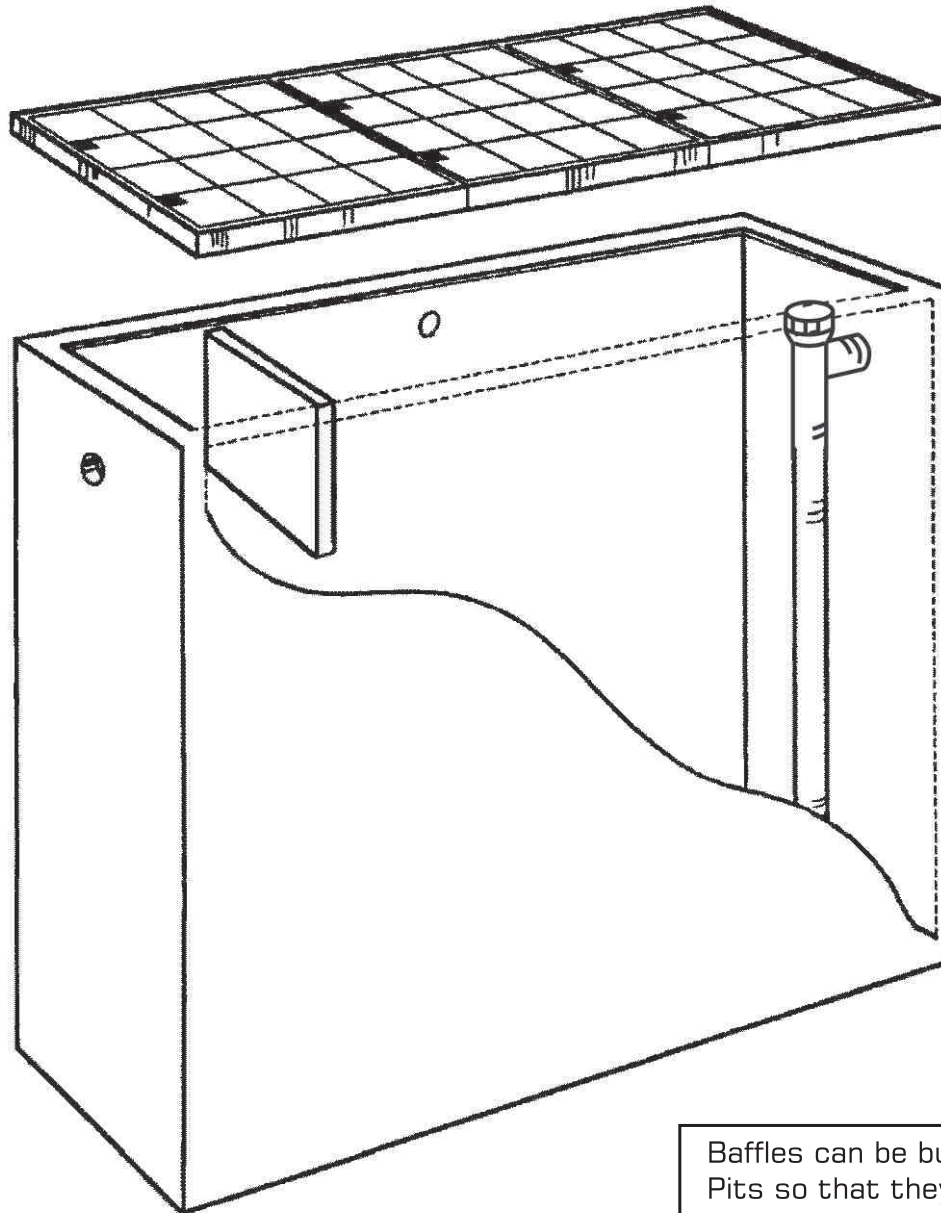

## Dimensions (in Millimetres)

Length	2300
Width	1050
Height	1700

Bottom of Tank to  
bottom of Inlet 1340

## Excavation Details

Length	2900
Width	1200

Lay unit on 75mm  
Deep Compacted Sand  
if required.

## Depth with Lids

Light Duty	1758
Medium Duty	1783
Heavy Duty	1783

All dimensions +/- 20mm

Baffles can be built into Trade Waste  
Pits so that they can be used for  
Storm Water Retention Pits

TITLE: 2000 Litre Grease Interceptor

Scale NTS	DATE 5 / 3 / 99
	DRW BY <i>[Signature]</i>
Drawing No CP026	CHECKED BY <i>[Signature]</i>
	DATE 5 / 3 / 99

Colac Cement Products PTY LTD  
Address: 21 Forest Street Colac, Victoria, 3250 Australia  
Phone: (03) 5231 5231  
Fax: (03) 5232 2744