

# ENVIROSEP 1500 Litre Petrol & Oil Interceptor

Drawing No.  
CP033

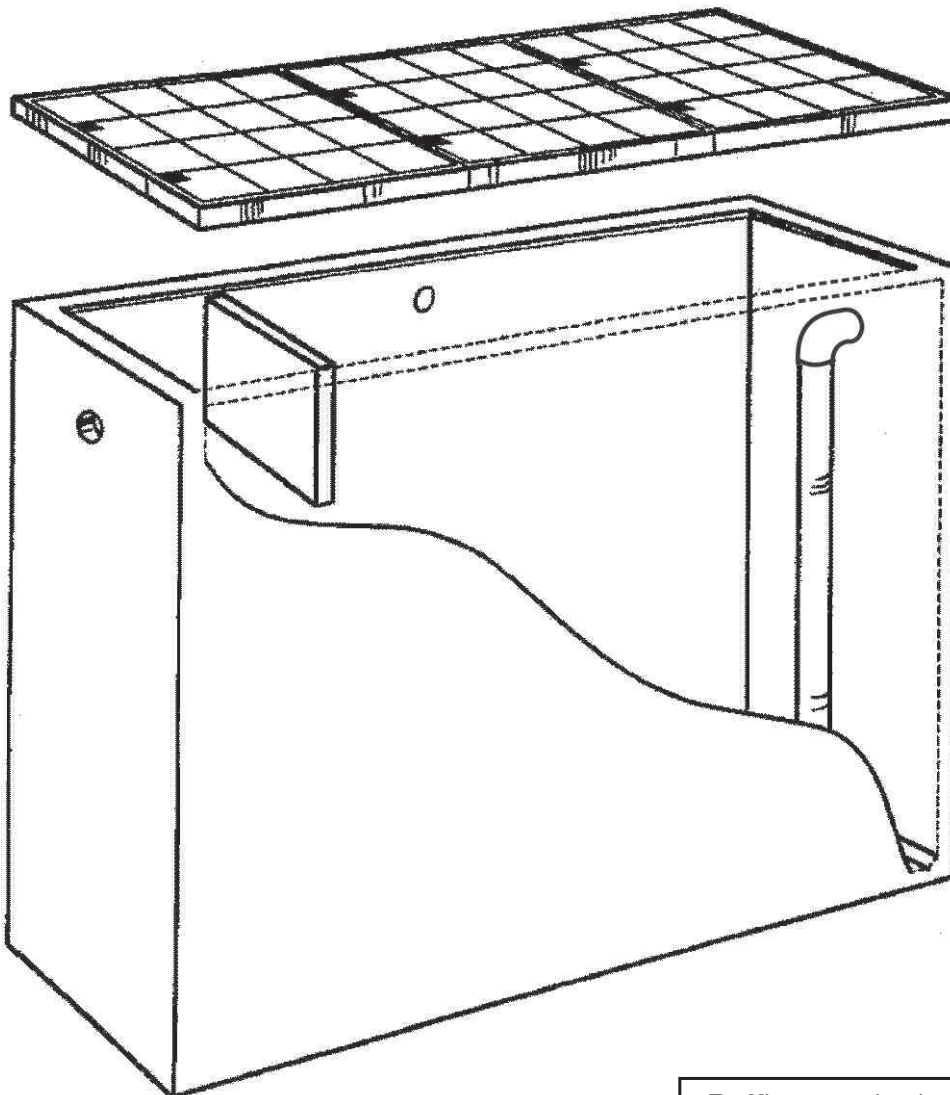

## Dimensions (in Millimetres)

### External

Length	2300
Width	1050
Height	1700

Bottom of Tank to bottom  
of Inlet 1340 external

### Excavation Details

Length	2600
Width	1250

Lay unit on 75mm  
Deep Compacted Sand  
if required.

### Depth with Lids

Light Duty	1758
Medium Duty	1783
Heavy Duty	1783

All dimensions +/- 20mm

Baffles can be built into Trade Waste  
Pits so that they can be used for  
Storm Water Retention Pits

Title: 1500 Litre Petrol & oil Interceptor

Scale NTS	DATE	5 / 3 / 99
	DRW BY	<i>[Signature]</i>
Drawing No CP033	CHECKED BY	<i>[Signature]</i>
	DATE	5 / 3 / 99

Colac Cement Products PTY LTD

Address: Phone: (03) 5231 5231  
21 Forest Street Fax: (03) 5232 2744  
Colac, Victoria, 3250  
Australia