

ENVIROSEP 1100 Litre Petrol & Oil Interceptor

Drawing No.
CP032

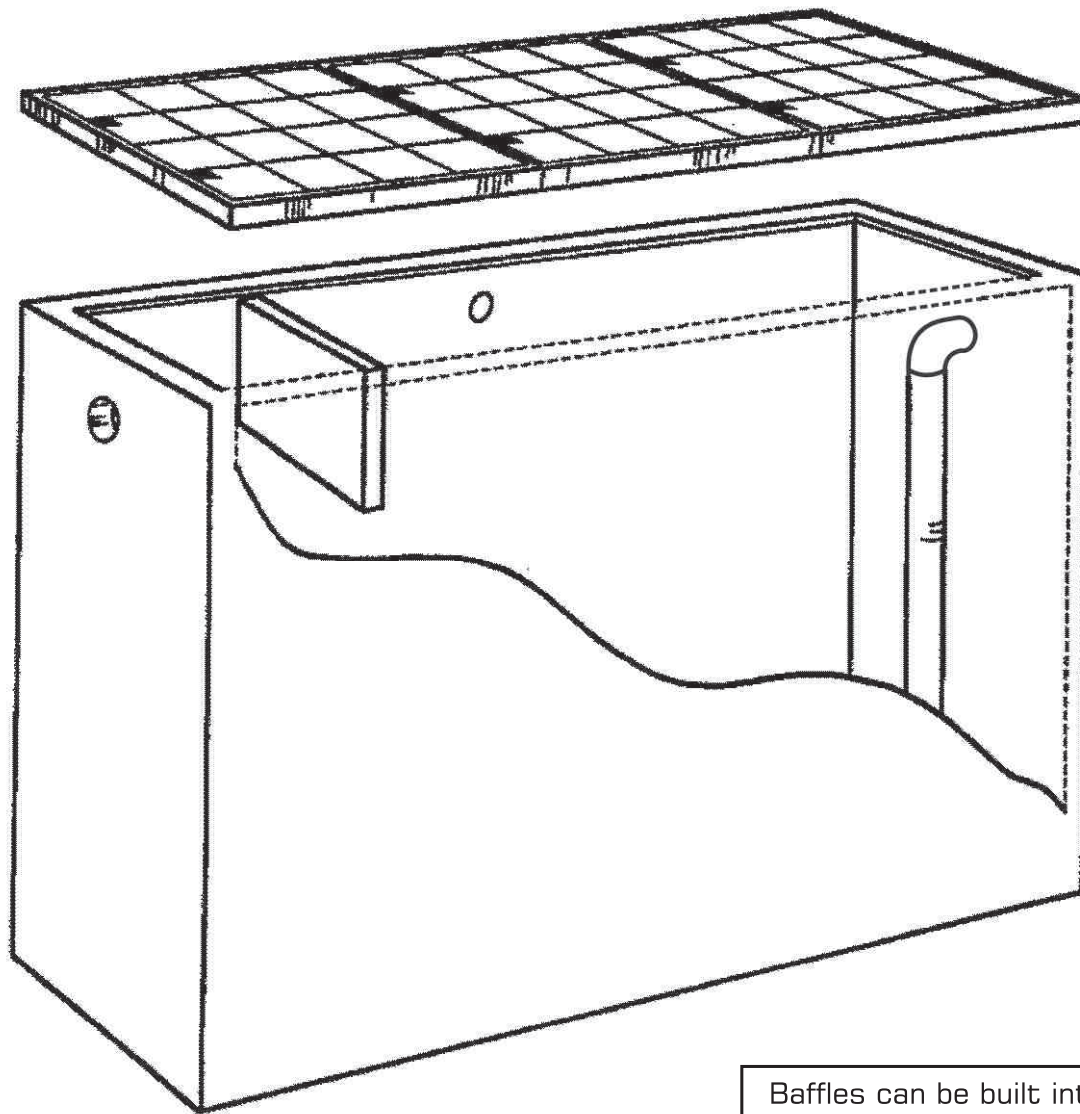

Dimensions (in Millimetres)

Length	1750
Width	1100
Height	1310

Bottom of Tank to bottom
of Inlet 1000 external

Excavation Details

Length	2050
Width	1300

Lay unit on 75mm
Deep Compacted Sand
if required.

Depth with Lids

Light Duty	1368
Medium Duty	1393
Heavy Duty	1393

All dimensions +/- 20mm

Baffles can be built into Trade Waste
Pits so that they can be used for
Storm Water Retention Pits

Title: 1100 Litre Petrol & Oil Interceptor	
Scale NTS	DATE 5 / 3 / 99
	DRW BY <i>[Signature]</i>
Drawing No CP032	CHECKED BY <i>[Signature]</i>
	DATE 5 / 3 / 99

Colac Cement Products PTY LTD
Address: Phone: (03) 5231 5231
21 Forest Street Fax: (03) 5232 2744
Colac, Victoria, 3250
Australia